

LATCHING TECHNOLOGY

Capable of holding in position without the constant application of electrical current. Latching technology is well suited for battery operated applications.

HIGH SPEED TECHNOLOGY

For applications requiring extremely accurate and high speed control of fluids, position or pressure. TLX's technology allows for response times in as little as 200 microseconds.

PROPORTIONAL TECHNOLOGY

For applications requiring accurate and repeatable control, low hysteresis, and a flat force vs. stroke curve. TLX's technology allows for a smaller package size for the same force requirement.

HIGH TEMPERATURE TECHNOLOGY

For applications requiring consistent performance under extremely high operating temperatures. TLX's high temperature technology offers proven operation in ambient temperatures exceeding 500°F (260°C).



Working with TLX Technologies

TLX Technologies engineers and manufactures custom solenoids, actuators and fluid control valves utilizing patented technology features that provide our customers with unique design solutions that offer them a competitive advantage.

Our strength has always been in the continued development of unique and progressive technology that provides exceptional opportunities for growth and expansion within markets utilizing electro-mechanical actuators while providing our customers with effective solutions that are energy efficient and cost competitive.

Typical Applications

- Proportional Pressure or Vacuum Control
- EGR Control
- Turbo Wastegate Control

Features & Benefits

- Pulse width modulated, proportional flow control
- Compact fully encapsulated design
- Can be optimized for specific pressure/vacuum ranges to optimize controllability
- Can be optimized to configure to customer's electronic drivers

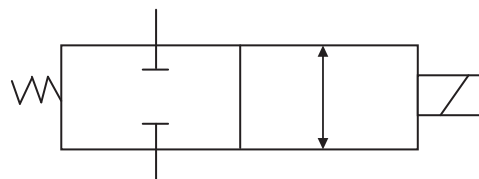
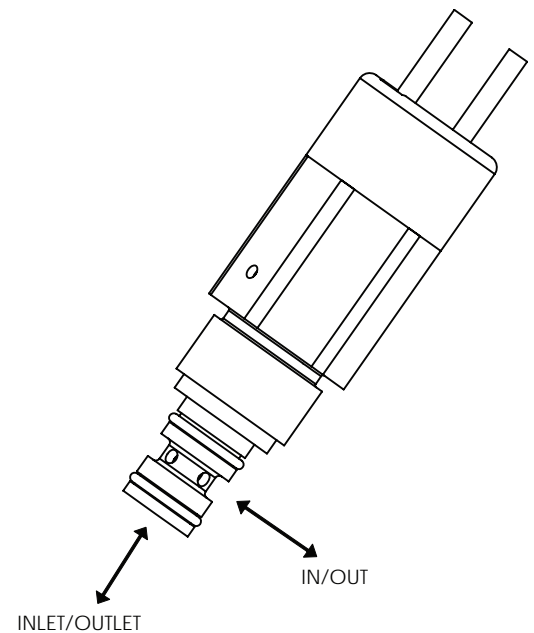

Proportional Pneumatic Control Valve

Typical Specifications (Custom configurations available)

Operation Limits

Operating Voltage	24 Vdc Nominal
Operating Pressure Range	-3 to 124 kPa
Operating Temperature	-40 to 150° F

Electrical

Operating Frequency	Continuous Rated
Resistance	131 ohms @ 20° C

Functional

Flow Rate	24 l/min @ 80 kPa
Leak Rate	< 1 cc/min
PWM Pressure Control	10-90% Duty Cycle
PWM Vacuum Control	10-90% Duty Cycle
Response Time	< 3 ms

Mechanical

Burst Pressure	25 bar
Vibration	50-400 Hz @ 20 G peak

Contact Us

*TLX Technologies, LLC
N27 W23727 Paul Road
Pewaukee, WI 53072*

*P: 262-970-8660
F: 262-970-8665
E: sales@tlxtech.com
W: www.tlxtech.com*



Contact TLX to discuss your project or ask our technical team any questions you may have.

TLX TECHNOLOGIES

An innovative, technology-centric producer of customized electro-mechanical actuation components. We use proportional, high-speed, high temperature and latching technologies to design custom electromagnetic solenoid products to meet a customer's specific needs.

PROGRESSIVE TECHNOLOGY

TLX Technologies' innovative design and customer-focused approach offers the advantage of faster response times, higher efficiency, increased accuracy, higher temperature tolerance, lower costs and a smaller footprint.

DESIGN EXPERTISE

With almost 150 years of combined experience in engineering and developing custom solenoid solutions for a wide variety of applications, our technical team partners with customers to lend our expertise to their development projects.

QUALITY

TLX's engineering team analyzes your application and desired specifications against design and manufacturing capabilities to assess manufacturability, usability, safety and quality so that the best solution is designed for your application.